

ART. S001
90° THREE FLUTES COUNTERSINK SET

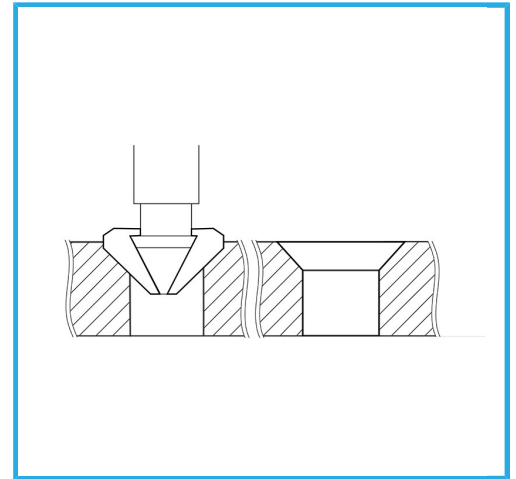

WITH GROUND EDGES AND GROOVES MACHINED FROM SOLID, TO PERFORM CONICAL COUNTERSINKS WITHOUT VIBRATIONS.



Ø max 6 - 8 - 10 - 12,4 - 16,5 - 20,5 mm
Gross weight 0,48 kg
Packaging dimensions 145x105x45 h mm
EAN Code 8012667183257

	Hangable		90°
	External		6 Pcs
	335C		-
	-		