

MIT MUFFENANSCHLUSS, EMPFOHLEN FÜR DEN EINSATZ AN MASCHINEN MIT REDUZIERTER LEISTUNG.

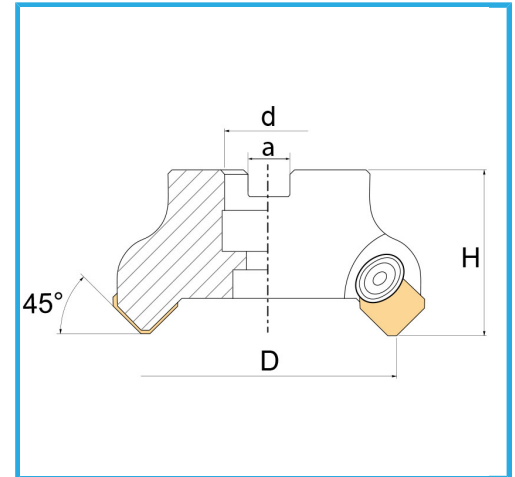

D	50 mm
H	48 mm
a	10,4 mm
d	22 mm
Z	4
Schraube	VTN00440
Einlegeboden	WSSP
Einsatz (nicht im Lieferumfang enthalten)	SEKN1203...
Bruttogewicht	0,59 kg
Verpackungsmaße	70x70x95 h mm
EAN-Code	8012667253189

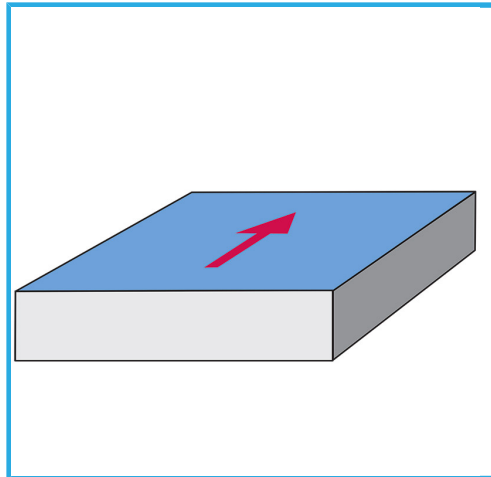

Box



Satiniert



Vernickelt



Extern